

COMPATIBILITY

Augers Compatible with BoRH Attachments

The BoRH™ is compatible with Aggressor® augers made with a one-piece cast auger head. The auger head acts as the tooth and pilot mounting platform. Below are things to look for when determining if your auger is compatible with the BoRH™ system.

- The height of the new pilot adapter (Dimension A) is 2-1/2". If this dimension is 1-1/2", then the auger head was fabricated and may not work well with the BoRH™ attachment.
 - If there is a weld bead in the areas pointed out with B, then the auger head was fabricated and may not work well with the BoRH™ attachment.
 - The compatible 1 piece cast auger head will have cast raised lettering in Area C. The lettering will have the auger diameter followed by a "-AR". Directly below that will be a part number that ranges from 137692 - 137697 depending on size. If your auger does not have those markings, then the Auger Head was fabricated and may not work well with the BoRH™ attachment.
- NOTE: If the auger has excessive wear, the lettering may no longer be present. In those cases, refer to A & B to determine compatibility.

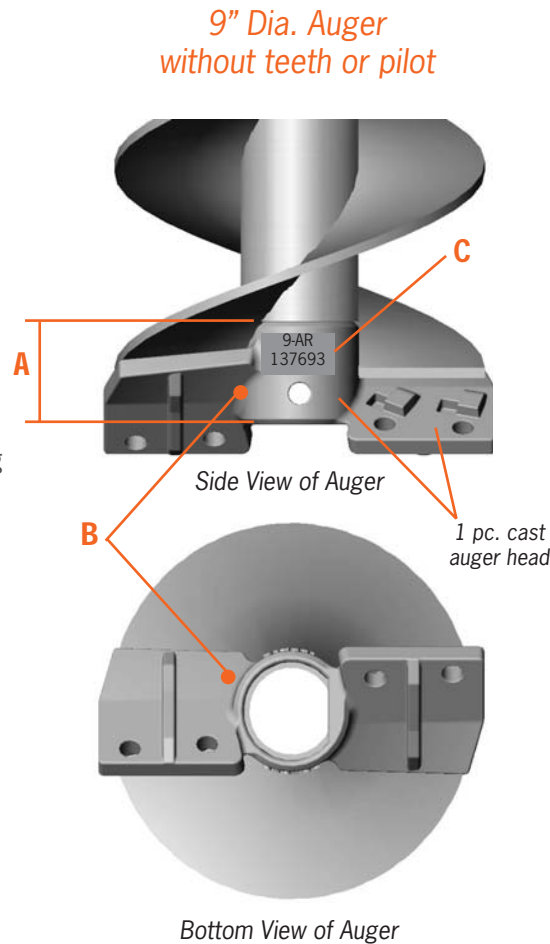

Instructions to convert PENGO Dirt Aggressor® Auger Into a Rock Auger

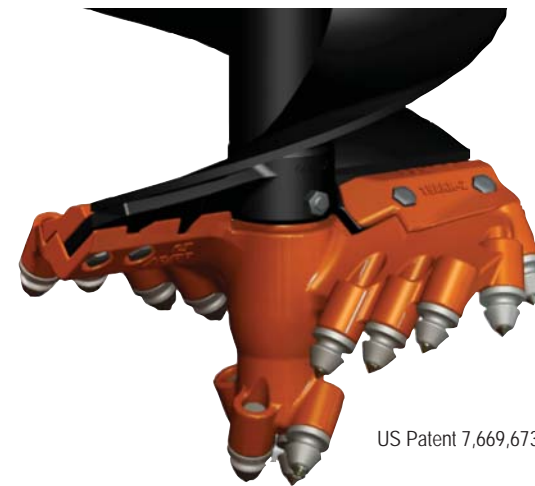

www.pengoattachments.com
800.599.0211

INSTRUCTIONS

STEP ONE Remove Dirt Components

Remove the Pengo® TriFlow® Pilot Bit & 40/50 Teeth as shown by removing 1/2" Nuts & Bolts with 3/4" wrench or socket.

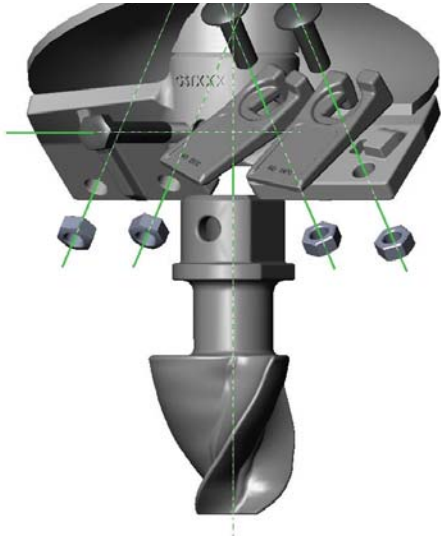

Auger head without pilot & teeth.

STEP TWO Install Rock Head

Insert Cast Rock Head into Auger Head and secure into place with 1/2" Nut & Bolt through center of auger as shown below. Make sure rock head is orientated so that the holes in the rock head line up with the holes in the Auger head.

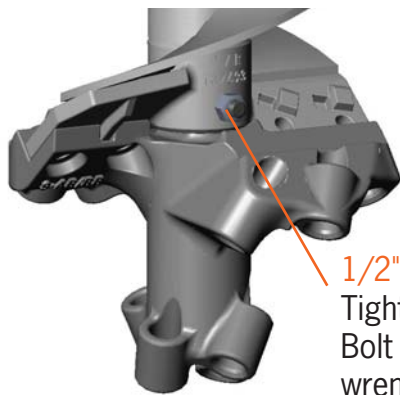

1/2" Bolt
Tighten Nut onto Bolt with 3/4" wrenches



STEP THREE Install Wear Caps

Place Wear Caps onto Dirt/Rock Head as shown below. Make sure that the holes in the wear caps line up with the holes in the auger and rock head. Place 1/2" x 1-1/4" Hex Bolts into wear caps so that the hex head seats in the hex recesses of caps. Tighten 1/2" nuts onto bolts placed on underside of rock head with 3/4" thin-walled socket.

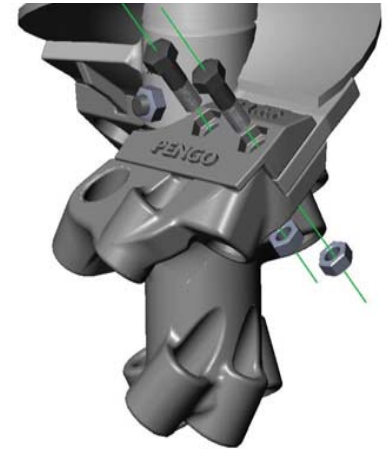
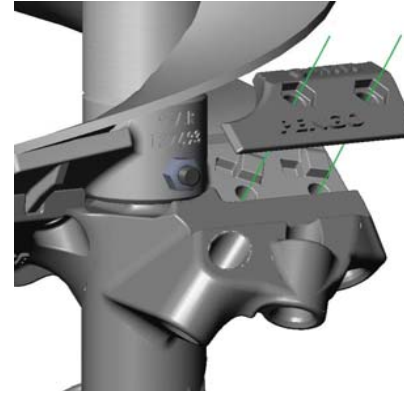

REPLACING TEETH

NOTE: BoRH™ head comes with the P-21 RR tooth installed. To replace teeth remove the worn teeth by using the Pengo® Drift Punch tool to pop teeth out of holders. Insert the P-21 RR tooth into the cylindrical holders of the cast head and secure by using the Pengo® SH-85 soft hammer.



Description		Part No.
6-BORH	Auger Kit	137991
9-BORH	Auger Kit	137992
12-BORH	Auger Kit	137993
15-BORH	Auger Kit	137994
18-BORH	Auger Kit	137995
24-BORH	Auger Kit	137996
P21-RR	Carbide tooth	137990
1225	Drift Punch	137750
SH85	Soft Hammer	137737