

## DRILLING | MS-125

### FEATURES

- Single Speed
- Compact Size
- Universal Compact Skid Mount Included
- Hydraulic Hoses Included



PART NO.	MODEL	CONNECTION	SWIVEL TYPE
700106	MS-125	R-256	Single
700303	MS-125	R-256	Double
700153	MS-125	H-200	Single
700313	MS-125	H-200	Double

### ACCESSORIES

700215 Double Swivel Bracket Assembly

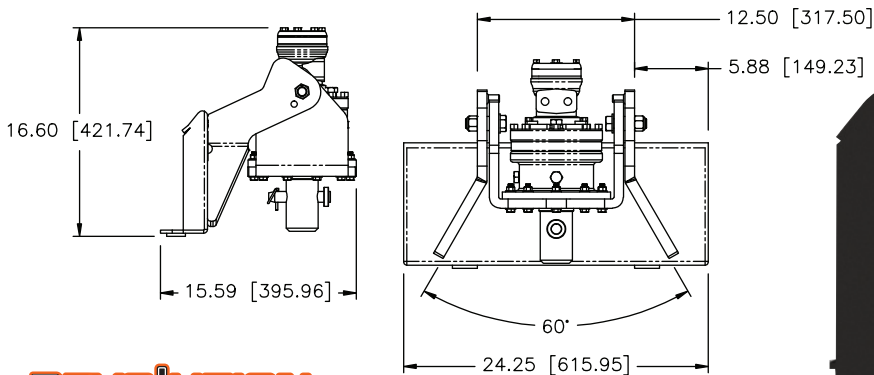

**REVOLUTION**  
SERIES

TOTAL UNIT WEIGHT	146 LBS / 66 Kg
HYDRAULIC MOTOR INFORMATION	
Displacement	7.3 cu/in (120cc)
Motor Type	Single Speed Bi-Directional
Motor Output Shaft	7/8" Spline 14T
Motor Mount	SAE - A 2 Bolt
Motor Ports	7/8" - 14 O-Ring
Cross Over Pressure Relief	Not Equipped
PLANETARY GEARBOX INFORMATION	
Gearbox Type	Planetary Single Stage
Reduction Ratio	5.77:1
Output Shaft	2" Hex or 2-9/16" Round
Oil Capacity	.31 Gallons
Oil Type	SAE 80W90 GL-5

REFERENCE TORQUE CHART		
Pressure PSI (Bar)	Torque (ft/lbs)	
1600 (110)	736	
1800 (124)	827	
2000 (137)	919	
2200 (151)	1011	
2400 (165)	1103	
2600 (179)	1195	
2800 (193)	1287	
3000 (206)	1378	

REFERENCE SPEED CHART		
Flow GPM (Liter)	Speed (rpm)	
10 (38)	45	
15 (56)	67	
20 (75)	90	
25 (94)	112	

Output speed and torque specifications are NOT listed at 100% efficiency. Actual efficiency may vary. Efficiency charts are provided in the manual and speed charts according to the manufacturer's recommendations. Speed and torque output are dependent on the system efficiency associated with the prime mover and Pengo system. Where the purchaser determines that the information provided herein is insufficient for their intended purpose, other product literature or other information may be required. This document should be used for information and comparative purposes only. When application specific information is required, please contact Pengo.