

# MDT-12K PLANETARY DRIVE - two speed

Pengo Part No. 660836 auto shift  
(12K, Closed Bail 45mm)

## Torque / Speed Chart

### Reference Torque Chart (HT/LS)

Pressure (psi)	Torque (ft/lb)
1000	5466
1200	6559
1400	7652
1600	8746
1800	9839
2000	10932
2200	12025
2400	13119

### Reference Torque Chart (LT/HS)

Pressure (psi)	Torque (ft/lb)
1000	2733
1200	3279
1400	3826
1600	4373
1800	4919
2000	5466
2200	6012
2400	6559

### Reference Speed Chart (low)

Flow (gpm)	Speed (rpm)
20	11.21
25	14.02
30	16.82
35	19.62
40	22.43

### Reference Speed Chart (high)

Flow (gpm)	Speed (rpm)
20	22.43
25	28.03
30	33.64
35	39.25
40	44.85

### TECHNICAL SPECIFICATIONS

Motor Mount:	SAE "C" 4 BOLT
Motors:	TWO SPEED
Rated Output Torque:	12,000 / 6,000 FT-LB (16,300 / 8,150 N-m)
Max System Pressure:	2,400 psi (165 bar)
Max Flow:	40 GPM (151 lpm)
Output Shaft:	2-1/2" Hex Shaft (HARDENED)
Shaft Pull-Out Load:	22,500 lb (10,000 kg)
Shaft Pressure Load:	22,500 lb (10,000 kg)
Oil Capacity:	11.8 pts (5.6l)
Weight:	264 lbs (120 kg) with Hydraulic Motor
Gear Ratio:	34.62:1

*Output speed and torque specifications are based on theoretical 100% values and are provided for comparative purposes only.*

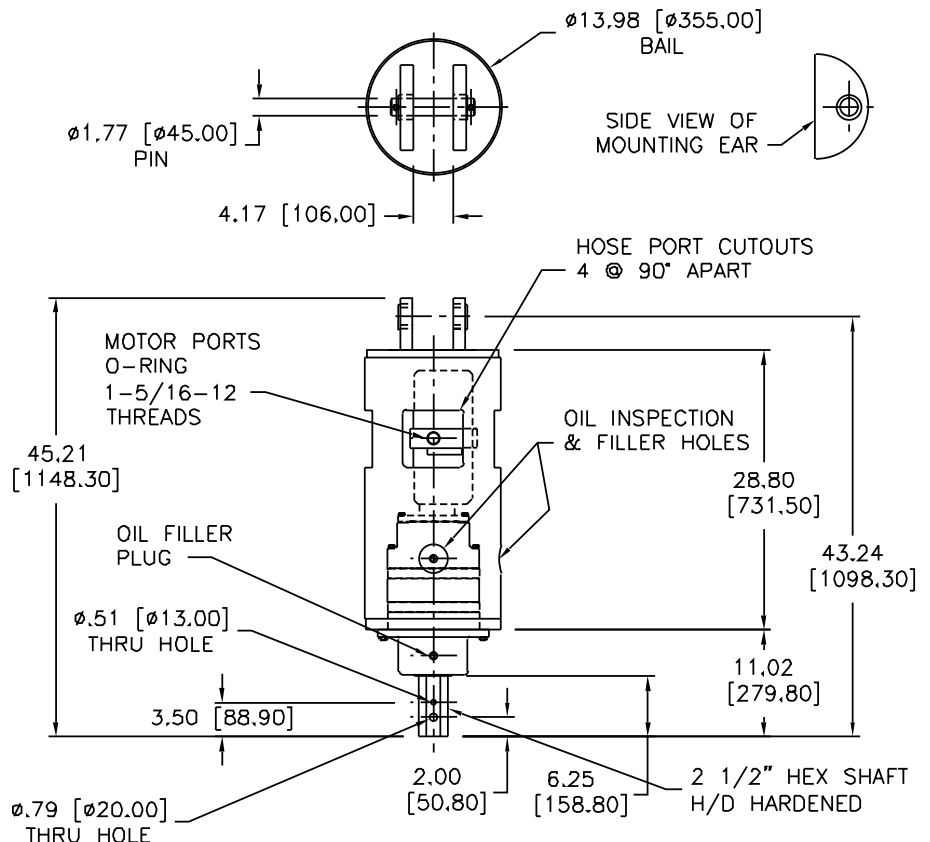

Note: MDT Units do not require a case drain.  
MDT Units must have a minimum of 20GPM to operate properly.



500 E. Highway 10, Laurens, IA 50554 - 800.599.0211  
email: pengosales@paladinbrands.com www.pengoattachments.com